

Rod Ends and Spherical Plain Bearings for Motor Sport



FLURO-Gelenklager GmbH

Introduction

The **FLURO** production program consists of Rod Ends to DIN ISO 12240 - 4 and Spherical Plain Bearings to DIN ISO 12240 - 1, Series K and E. Stainless steel, maintenance free and versions with lubrication fittings are available. Where bearings with standard dimensions cannot be used, parts to customer designs are manufactured.

Since many years the **FLURO** products have achieved a reputation of high quality and durability. Therefore the demand within the industrial application market continuously increased. Market observation and customer requests initiated the development and design of a Motor Sport product.

Technical research and continuous product development enabled FLURO to establish a product version exclusively designed for motor sport applications.

On the following pages Rod Ends and Spherical Plain Bearings are introduced, which have already proven itself in Motor Sport applications.

For Rod Ends and Spherical Plain Bearings for the industrial application sector, please refer to FLURO's general catalogue which is available on request.

Recently our industrial plant was enlarged and modernized. This means advanced improvements to our logistics and an enlarged stock of products for faster production and delivery response.

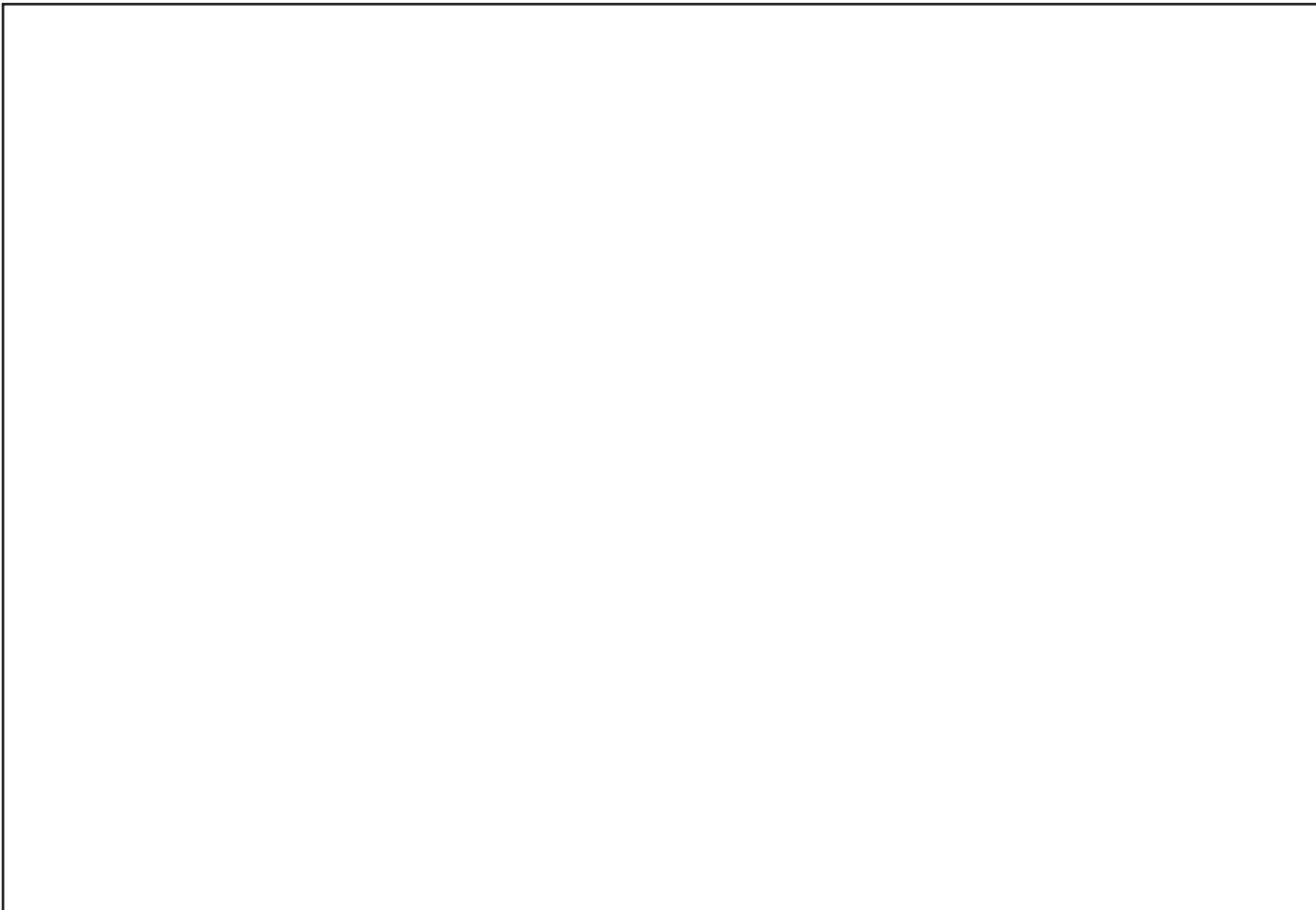

Contents

General

Introduction	2
Contents	3
Production Program, Technical Data	4
Applications	5

Motor Sport Rod Ends Series K

GIXSW..MS	MS-Version, female thread, Maintenance Free	6
GAXSW..MS	MS-Version, male thread, Maintenance Free	7

Motor Sport Spherical Plain Bearings Series K

GXSW..MS	MS-Version, smaller outside diameter, Maintenance Free	8
GXOW..MS	MS-Version, larger outside diameter, Maintenance Free	9
GLRSW..MS	MS-Version, with Outer Ring, Maintenance Free	10

Spherical Plain Bearings Series K

GXO..	Extra heavy duty, larger outside diameter, Steel on Steel, regreasable	11
GXO..RR	Extra heavy duty, larger outside diameter, Steel on Steel, regreasable Stainless Steel	

Motor Sport Spherical Plain Bearings Series E

GE..EC-NIRO MS	MS-Version, Maintenance Free, Stainless Steel	12
----------------	---	----

Additional Versions	13
Inquiry Template Special Parts	14
Specialties	15



Motor Sport Catalogue Edition 2004

Every care has been taken to ensure the accuracy of the information in this catalogue.

However no liability can be accepted for any errors or omissions.

Due to continuing technical advances we reserve the right to alter our products without notice.

www.fluro.de

Production Program - Technical Data

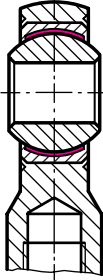
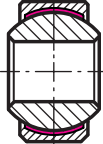
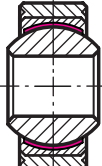
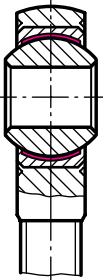
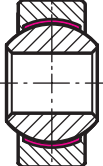
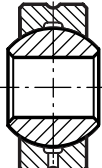
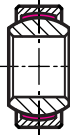
Rod Ends DIN ISO 12240-4 Series K - Motor Sport			Spherical Plain Bearings DIN ISO 12240-1 Series K - Motor Sport			Spherical Plain Bearings DIN ISO 12240-1 Series K - Motor Sport		
GIXSW ..MS	Rod Ends with female thread maintenance free		GXSW..MS	Spherical Plain Bearings smaller outside-Ø		GLRSW ..MS	Spherical Plain Bearings larger outside-Ø	
GAXSW ..MS	Rod Ends with male thread maintenance free		GXOW..MS	Spherical Plain Bearings larger outside-Ø		Spherical Plain Bearings DIN ISO 12240-1 Series K - Extra Heavy Duty		
						GXO..(RR)	Spherical Plain Bearings larger outside-Ø, Steel on Steel	
						Spherical Plain Bearings DIN ISO 12240-1 Series E - Motor Sport		
						GE..EC- NIRO MS	Spherical Plain Bearing maintenance free	

Characteristics of MS - Series:

Preloaded bearing fit

An internal play with 'zero' tolerance is achieved through a preloaded bearing. Under normal permissible conditions and usage a minimal settlement of the bearing components or a minimal tolerance increase at the mating surface will take place. This special bearing technology causes a considerably higher bearing life with continuous low internal clearance. However MS-Spherical Plain Bearings are not suited for rotation as well as very high swivel frequency.

Please note that the series GXO..(RR) is not a preloaded bearing version, but the clearance is reduced to a minimal fit.

Surface

The nickel plated housing surface with a high polish finish achieves a sporty appealing design, especially on visible components. This high-quality surface treatment with high corrosion resistance minimizes the sedimentation of dirt and is easy to clean.

Lubrication

Maintenance Free Rod Ends and Spherical Plain Bearings must not be lubricated. The ball revolves on a PTFE liner incorporated in the Insert.

Regreasable Rod Ends and Spherical Plain Bearings require regular usage-orientated lubrication depending on the application. The first time lubrication has to be carried out when the part is mounted.

Examination:

Upon customer requirements the parts can be checked against cracks.

Applications

The Motor Sport application has its own demand on product and technique. The required task is to create a product which combines high performance and an appealing sporty design. Animated through customers and in close contact with technicians and university development teams FLURO developed this MS series. For the below mentioned applications the technical geometric design in connection with the performance of the bearing becomes important. A special emphasis has to be laid on the bearing's composition of inner ring, insert, mating surface and housing.

A classic application for Rod Ends is the suspension system. Related to it are different load problems such as vibrations and shocks under radial or axial loads. This dynamic stress demands a technically high quality bearing.

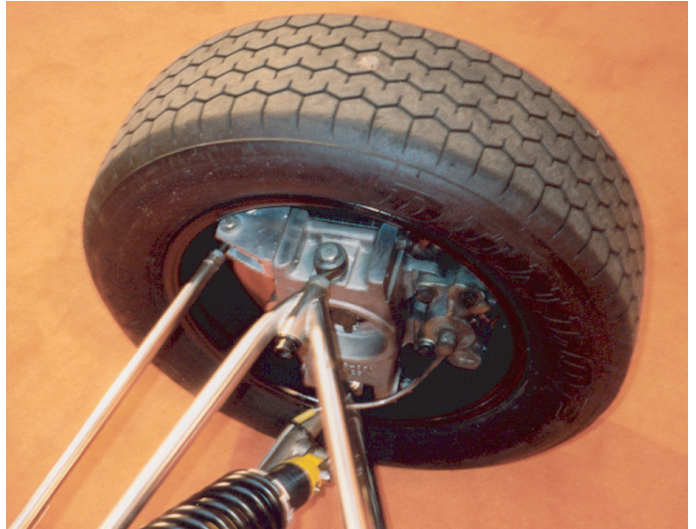

Depending on the race course and the driving performance of the driver, different loads can occur on the steering system.

In addition racing vehicles require a sporty design and appearance. The nickel plated housing with a high polish finish offers a professional racing look and is easy to clean from dirt and grease.

For motor cycles Rod Ends and Spherical Plain Bearings are used as stabilizers, for rod linkages and steering devices.

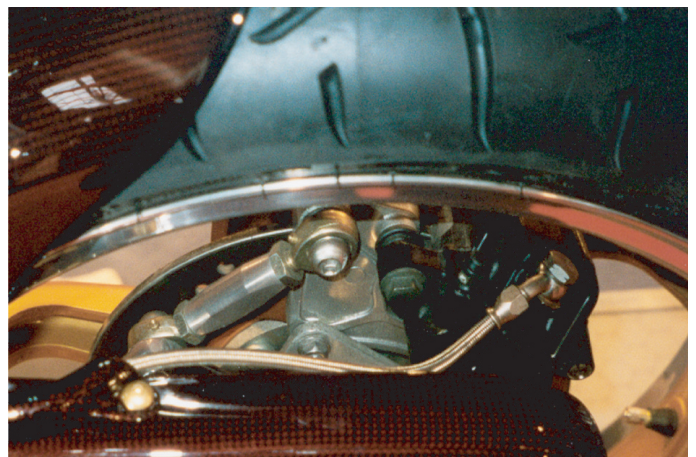

Rod Ends Motor Sport Maintenance Free

Series GIXSW..MS

Rod Ends with female thread made from heat-treated steel, nickel plated with PTFE-liner, maintenance free.
Preloaded bearing

For use at highest dynamic pressure and tension loads in corrosive environments

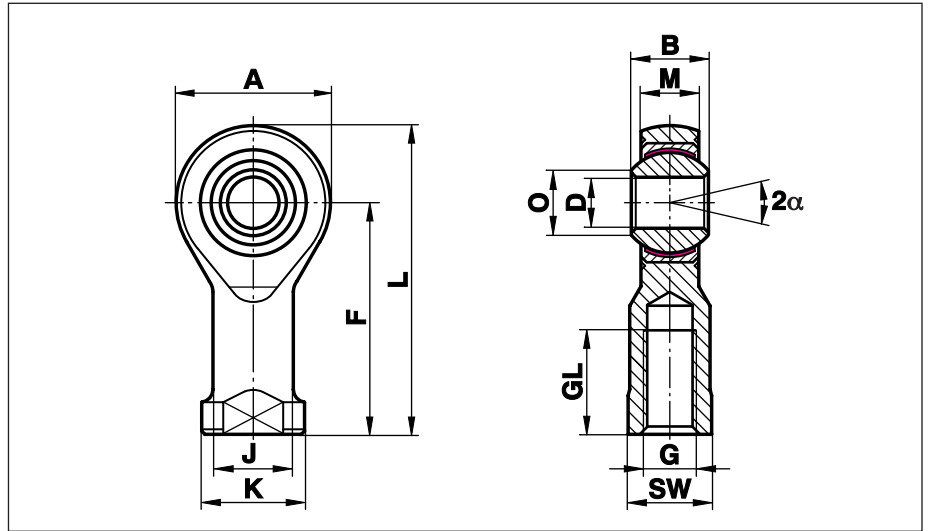

Description	DH7	B	M	A	F	L	K	J	O	SW	G	GL	static radial load C ₀ kN	dynamic radial load C ₀ kN	α	weight gr
GIXSW 8 MS	8	12	9,0	24	36	48	16	12,5	10,4	13	M 8x1,25	16	25,5	20,0	14°	46
GIXSW 10x1,25 MS	10	14	10,5	28	43	57	19	15,0	12,9	17	M 10x1,25	20	34,8	28,1	13°	76
GIXSW 10 MS	10	14	10,5	28	43	57	19	15,0	12,9	17	M 10x1,5	20	34,8	28,1	13°	76
GIXSW 12x1,25 MS	12	16	12,0	32	50	66	22	17,5	15,4	19	M 12x1,25	22	42,0	38,4	13°	115
GIXSW 12 MS	12	16	12,0	32	50	66	22	17,5	15,4	19	M 12x1,75	22	42,0	38,4	13°	115
GIXSW 14 MS	14	19	13,5	36	57	75	25	20,0	16,8	22	M 14x2	25	57,0	50,5	16°	170
GIXSW 16 MS	16	21	15,0	42	64	85	27	22,0	19,3	22	M 16x2	28	67,5	63,0	15°	230
GIXSW 18 MS	18	23	16,5	46	71	94	31	25,0	21,8	27	M 18x1,5	32	81,5	76,5	15°	320
GIXSW 20 MS	20	25	18,0	50	77	102	34	27,5	24,3	32	M 20x1,5	33	93,5	93,5	14°	415

Materials:

Housing: Heat-treated steel to 42CrMo4, Aisi 4140 forged, nickel plated with high polish finish.

Insert: Stainless steel to 1.4571, Aisi 316Ti with PTFE liner bonded to the inner surface

Ball: Bearing steel to 100Cr6, Aisi 52100 hardened, ground, polished, hard chrome plated

Clearance: preloaded, zero tolerance

On request:

- with left hand thread
- Rod End with reduced bore (D)
- with threaded bolt
- further sizes are available

Rod End Motor Sport Maintenance Free

Series GAXSW..MS

Rod Ends with male thread made from heat-treated steel, nickel plated with PTFE-liner, maintenance free. Preloaded bearing

For use at highest dynamic pressure and tension loads in corrosive environments

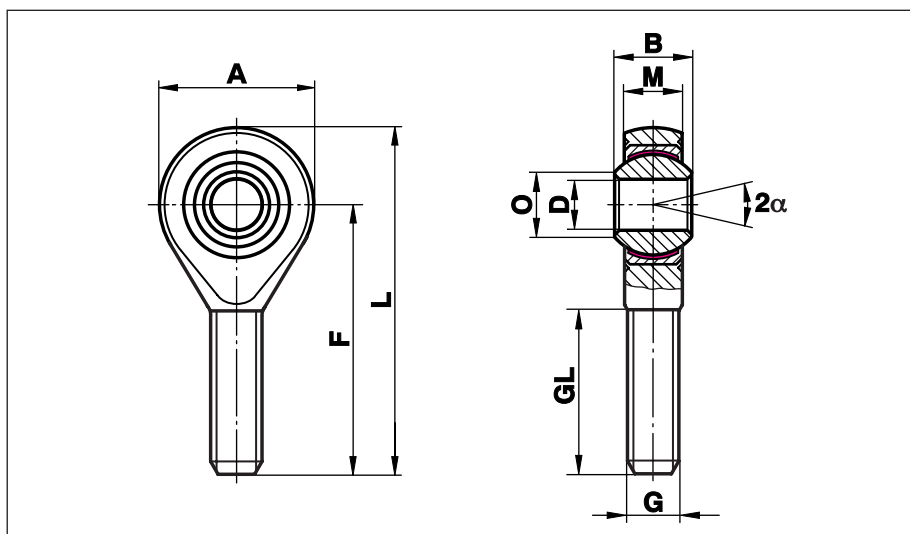

Description	DH7	B	M	A	F	L	O	G	GL	static radial load C ₀ kN	dynamic radial load C ₀ kN	α	weight gr
GAXSW 6 MS	6	9	6,75	20	36	46	8,9	M 6x1	22	9,8	9,8	13°	20
GAXSW 8 MS	8	12	9,00	24	42	54	10,4	M 8 x1,25	25	19,5	19,5	14°	33
GAXSW 8x1 MS	8	12	9,00	24	42	54	10,4	M 8 x1	25	19,5	19,5	14°	33
GAXSW 10 MS	10	14	10,50	28	48	62	12,9	M 10x1,5	29	31,4	28,1	13°	56
GAXSW 10x1,25 MS	10	14	10,50	28	48	62	12,9	M 10x1,25	29	31,4	28,1	13°	56
GAXSW 10x1 MS	10	14	10,50	28	48	62	12,9	M 10x1	29	31,4	28,1	13°	56
GAXSW 12 MS	12	16	12,00	32	54	70	15,4	M 12x1,75	33	42,0	38,4	13°	87
GAXSW 12x1,5 MS	12	16	12,00	32	54	70	15,4	M 12x1,5	33	42,0	38,4	13°	87
GAXSW 12x1,25 MS	12	16	12,00	32	54	70	15,4	M 12x1,25	33	42,0	38,4	13°	87
GAXSW 14 MS	14	19	13,50	36	60	78	16,8	M 14x2	38	57,0	50,5	16°	129
GAXSW 14x1,5 MS	14	19	13,50	36	60	78	16,8	M 14x1,5	38	57,0	50,5	16°	129
GAXSW 16 MS	16	21	15,00	42	66	87	19,3	M 16x2	40	67,0	63,0	15°	189
GAXSW 16x1,5 MS	16	21	15,00	42	66	87	19,3	M 16x1,5	40	67,0	63,0	15°	189
GAXSW 18 MS	18	23	16,50	46	72	95	21,8	M 18x1,5	44	81,5	76,5	15°	267
GAXSW 20 MS	20	25	18,00	50	78	103	24,3	M 20x1,5	47	93,5	93,5	14°	348
GAXSW 25 MS	25	31	22,00	60	94	124	29,6	M 24x2	58	135,0	135,0	15°	600

Rod Ends with reduced bore:

Description	DH7	B	M	A	F	L	O	G	GL	static radial load C ₀ kN	dynamic radial load C ₀ kN	α ¹⁾	weight gr
GAXSW 10.8 MS	8	14	10,50	28	48	62	12,9	M 10x1	29	31,4	28,1	13°	56
GAXSW 12.10 MS	10	16	12,00	32	54	70	15,4	M 12x1,5	33	42,0	38,4	13°	87
GAXSW 14.12 MS	12	19	13,50	36	60	78	16,8	M 14x1,5	38	57,0	50,5	16°	129
GAXSW 16.14 MS	14	21	15,00	42	66	87	19,3	M 16x1,5	40	67,0	63,0	15°	189
GAXSW 18.16 MS	16	23	16,50	46	72	95	21,8	M 18x1,5	44	81,5	76,5	15°	267

Materials:

- Housing:** Heat-treated steel to 42CrMo4, Aisi 4140 forged, polished, nickel plated with high polish finish
Insert: Stainless steel to 1.4571, Aisi 316Ti with PTFE liner bonded to the inner surface
Ball: Bearing steel to 100Cr6, Aisi 52100 hardened, ground, polished, hard chrome plated
Clearance: preloaded, zero tolerance
On request: with left hand thread, threaded bolt and further sizes are available

¹⁾ The reduced bore diameter offers to the engineer the possibility to construct a bearing with a very high pivoting angle, especially when a minimal shaft collar is used (in some cases twice as high as standard listing).

Spherical Plain Bearings Motor Sport Maintenance Free

Series GXSW..MS

Spherical Plain Bearings
with smaller outside Ø,
maintenance free.
Preloaded Bearing

For use at highest
dynamic pressure and
tension loads in corrosive
environments

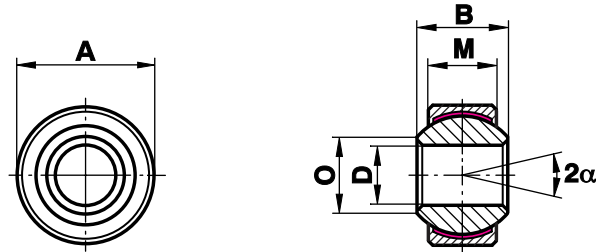

Description	DH7	B	M	A h6	O	static radial load C ₀ kN	dynamic radial load C ₀ kN	α	weight gr
GXSW 8.19 MS	8	12	9,00	19	10,4	27,8	20,8	14°	17
GXSW 10.22 MS	10	14	10,50	22	12,9	39,0	28,1	13°	26
GXSW 12.26 MS	12	16	12,00	26	15,4	53,5	38,4	13°	41
GXSW 14.29 MS	14	19	13,50	29	16,8	70,0	50,5	16°	56
GXSW 16.32 MS	16	21	15,00	32	19,3	88,0	63,0	15°	75
GXSW 18.35 MS	18	23	16,50	35	21,8	106,5	76,5	15°	97
GXSW 20.40 MS	20	25	18,00	40	24,3	130,0	93,5	14°	142

Materials:

- Insert:** Stainless steel to 1.4571, Aisi 316Ti with PTFE liner bonded to the inner surface
- Ball:** Bearing steel to 100Cr6, Aisi 52100 hardened, ground, polished, hard chrome plated
- Clearance:** preloaded, zero tolerance
- On request:**
- Ball made from stainless steel to 1.4034 Aisi 420 hardened, ground, polished
 - with V-Groove on both sides
 - with threaded bolt

Spherical Plain Bearings Motor Sport Maintenance Free

Series GXOW..MS

Spherical Plain Bearings with larger outside \varnothing , Insert from extra heavy-duty steel, zinc plated with PTFE-liner, maintenance free. Preloaded bearing

For use at highest dynamic pressure and tension loads

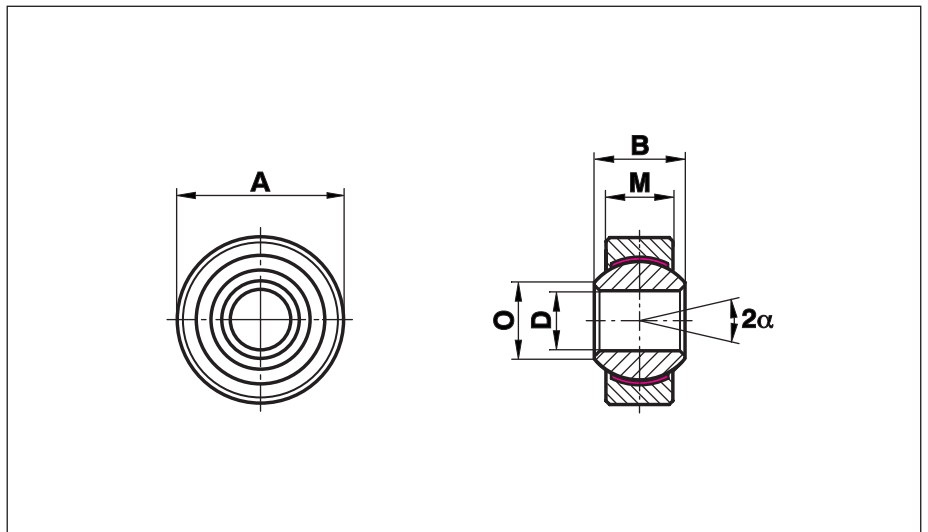

Description	DH7	B	M	A h6	O	static radial load C_0 kN	dynamic radial load C_0 kN	α	weight gr
GXOW 8.22 MS	8	12	9,00	22	10,4	27,8	20,8	14°	23
GXOW 10.26 MS	10	14	10,50	26	12,9	39,0	28,1	13°	38
GXOW 12.30 MS	12	16	12,00	30	15,4	53,5	38,4	13°	58
GXOW 14.34 MS	14	19	13,50	34	16,8	70,0	50,5	16°	83
GXOW 16.38 MS	16	21	15,00	38	19,3	88,0	63,0	15°	115
GXOW 18.42 MS	18	23	16,50	42	21,8	106,5	76,5	15°	150
GXOW 20.46 MS	20	25	18,00	46	24,3	130,0	93,5	14°	200

Materials:

Insert: Extra heavy-duty steel to 45S20, zinc plated

Ball: Bearing steel to 100Cr6, Aisi 52100 hardened, ground, polished, hard chrome plated

Clearance: preloaded, zero tolerance

On request:
 - with threaded bolt
 - with V-Groove on both sides

Spherical Plain Bearings Motor Sport Stainless, Maintenance Free

Series GLRSW..MS

Spherical Plain Bearings with larger outside \varnothing and outer ring with PTFE-liner, maintenance free. Preloaded bearing

For use at higher dynamic pressure and tension loads in corrosive environments

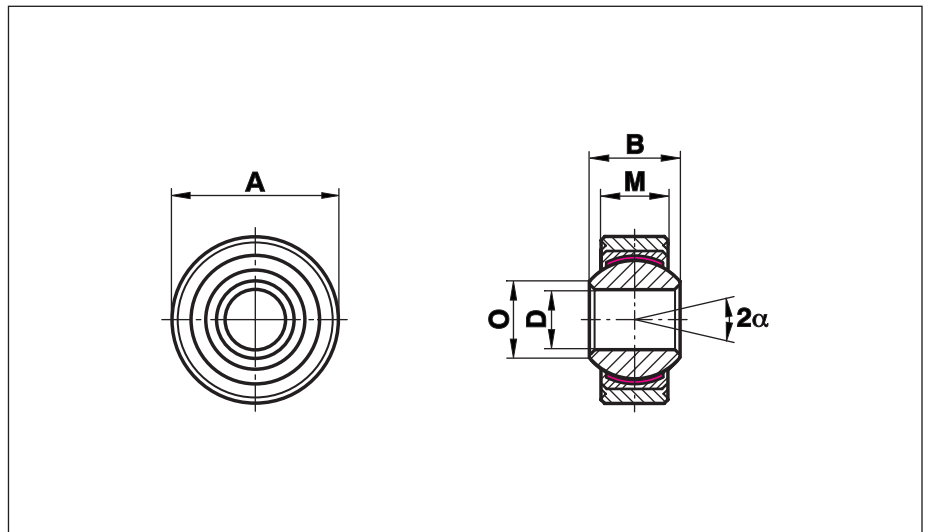

Description	DH7	B	M	A h6	O	static radial load C_0 kN	dynamic radial load C_0 kN	α	weight gr
GLRSW 8 MS	8	12	9,00	22	10,4	27,8	16,7	14°	23
GLRSW 10 MS	10	14	10,50	26	12,9	39,0	23,4	13°	38
GLRSW 12 MS	12	16	12,00	30	15,4	53,5	32,0	13°	58
GLRSW 14 MS	14	19	13,50	34	16,8	70,0	42,0	16°	83
GLRSW 16 MS	16	21	15,00	38	19,3	88,0	52,5	15°	115
GLRSW 18 MS	18	23	16,50	42	21,8	106,5	64,0	15°	150
GLRSW 20 MS	20	25	18,00	46	24,3	130,0	78,0	14°	200

Materials:

- Outer ring:** Stainless steel to 1.4305, Aisi 305, turned
- Insert:** Stainless steel to 1.4571, Aisi 316Ti with PTFE-liner bonded to the inner surface
- Ball:** Bearing steel to 100Cr6, Aisi 52100, hardened, ground, polished, hard chrome plated
- Clearance:** preloaded, zero tolerance
- On request:**
- Ball made from stainless steel to 1.4034 Aisi 420 hardened, ground, polished
 - with threaded bolt

Spherical Plain Bearings Extra Heavy Duty Steel on Steel, Stainless

Series GXO..(RR)

Spherical Plain Bearings with larger outside \varnothing , regreasable

For use at highest dynamic radial and **axial** pressure and tension loads. Vibration and impact resistant

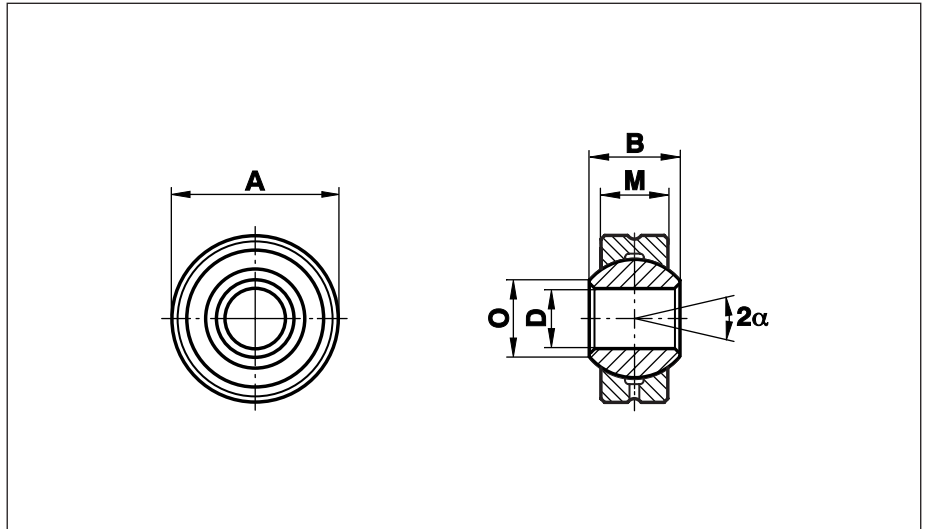

Description	DH7	B	M	A h6	O	static radial load C_0 kN	dynamic radial load C_0 kN	α	weight gr
GXO 8.22	8	12	9,00	22	10,4	60,7	7,1	14°	23
GXO 10.26	10	14	10,50	26	12,9	85,2	9,9	13°	38
GXO 12.30	12	16	12,00	30	15,4	113,5	13,0	13°	58
GXO 14.34	14	19	13,50	34	16,8	146,0	17,0	16°	83
GXO 16.38	16	21	15,00	38	19,3	182,5	21,0	15°	115
GXO 18.42	18	23	16,50	42	21,8	224,0	26,0	15°	150
GXO 20.46	20	25	18,00	46	24,3	268,0	31,0	14°	200

Materials:

Insert: Extra heavy-duty steel to 45S20, zinc plated

Ball: Bearing steel to 100Cr6, Aisi 52100 hardened, ground, polished, hard chrome plated

Clearance: minimal fit / smaller internal clearance

Description	DH7	B	M	A h6	O	static radial load C_0 kN	dynamic radial load C_0 kN	α	weight gr
GXO 8.22 RR	8	12	9,00	22	10,4	30,4	3,5	14°	23
GXO 10.26 RR	10	14	10,50	26	12,9	42,6	4,9	13°	38
GXO 12.30 RR	12	16	12,00	30	15,4	57,0	6,5	13°	58
GXO 14.34 RR	14	19	13,50	34	16,8	73,0	8,5	16°	83
GXO 16.38 RR	16	21	15,00	38	19,3	91,0	10,5	15°	115
GXO 18.42 RR	18	23	16,50	42	21,8	112,0	13,0	15°	150
GXO 20.46 RR	20	25	18,00	46	24,3	134,0	15,5	14°	200

Materials:

Insert: Stainless steel to 1.4571, Aisi 316Ti

Ball: Stainless steel to 1.4034, Aisi 420, hardened, ground, polished

Clearance: minimal fit / smaller internal clearance

Both series are also available with threaded bolt.

Spherical Plain Bearings Motor Sport-Stainless, Maintenance Free

Series **GE..EC-NIRO MS**

Spherical Plain Bearings, narrow series made from stainless steel running on PTFE, maintenance free

For use at dynamic pressure and tension loads in corrosive environments and limited fitting dimensions

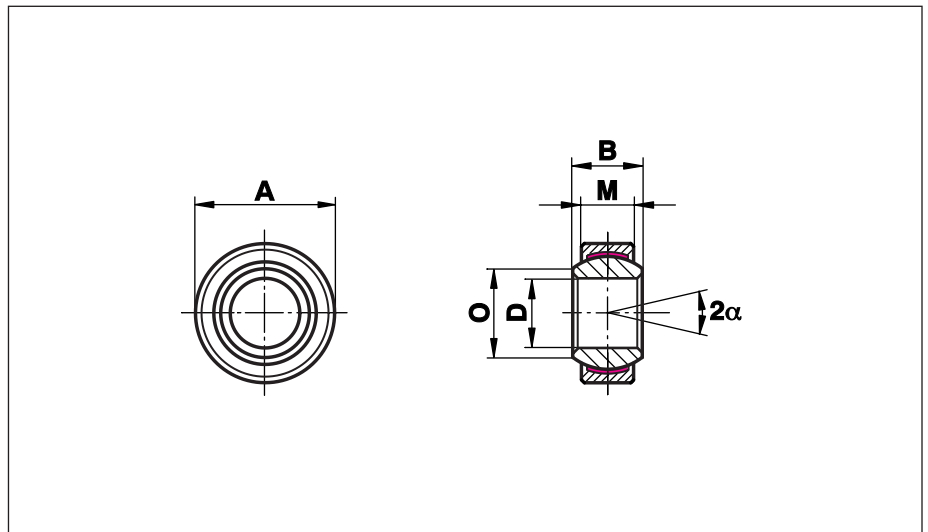

Description	D	B	M	A	O	static radial load C ₀ kN	dynamic radial load C ₀ kN	α	weight gr
GE 10 EC-NIRO MS	10 ⁰ _{-0,008}	9	6	19 ⁰ _{-0,009}	13,2	23,4	10,0	12°	11
GE 12 EC-NIRO MS	12 ⁰ _{-0,008}	10	7	22 ⁰ _{-0,009}	14,9	32,0	14,0	11°	16
GE 15 EC-NIRO MS	15 ⁰ _{-0,008}	12	9	26 ⁰ _{-0,009}	18,4	50,0	30,0	11°	26
GE 17 EC-NIRO MS	17 ⁰ _{-0,008}	14	10	30 ⁰ _{-0,009}	20,7	65,0	39,0	10°	38
GE 20 EC-NIRO MS	20 ⁰ _{-0,010}	16	12	35 ⁰ _{-0,011}	24,2	90,5	54,0	9°	61

Materials:

Insert: Stainless steel to 1.4571, Aisi 316Ti, with PTFE liner bonded to the inner surface

Ball: Stainless steel to 1.4125, hardened, ground, polished

Clearance: preloaded, zero tolerance

Additional Versions

Rubber Protector Caps made from Neoprene

- protective against dust, chemical substances and aggressive environment
- resistant to oil, grease, saltwater, chemical components and other substances
- temperature range from -20° till +120° Celsius or -4° till +248° Fahrenheit



Rod End with Spherical Plain Bearing with V - Groove.

- this version is used in units where damage or destruction of the housing's bore is to be avoided (suspension system, connecting rods etc.)
- when mounted properly an unnecessary load and a possible change of the bearing's geometric is avoided.
- already used in standard series Motor Sport applications, there is no increase of internal clearance even under higher dynamic loads, such as vibration and shocks etc.

Company: _____ Contact: _____ Phone: _____

Center Distance = _____ mm

Thickness $t =$ _____ mm (observe Spherical width!)
 Material: _____ with 2x Sphericals : _____

Please indicate: Form A Form B

Center Distance = _____ mm Adjustable Range = +/- _____ mm

Ridge to identify left hand thread
 Left hand thread
 Hexagon SW= _____ alternative: Pipe \varnothing _____ with cross bore
 Length= _____ mm Material: _____
 Lock Nut DIN 439 (flat) Material: _____
 Rod End _____

Center Distance = _____ mm Adjustable Range = +/- _____ mm

Left hand thread
 Threaded Rod Length= _____ mm Material: _____
 Lock Nut DIN 439 (flat) Material: _____
 Rod End _____

with incorporated Spherical Type: _____
 Head Width $M =$ _____ mm, Ball Width $B =$ _____ mm
 Thread Length $GL =$ _____ mm, Thread $G =$ _____

Material Ball: _____
 Material Outer Ring: _____
 Maintenance free: Yes No

Custom-Made Products

Rosenfeld is situated between the city of Stuttgart and the lake Bodensee, in southern Germany. You can get to us easily from the international airport of Stuttgart by car. Drive Highway A81 south (towards Singen), exit at Oberndorf and follow the road to Rosenfeld. Our company's plant is situated in the midst of an industrial area on the right hand side behind the town's entrance. We invite you to pay a visit at our manufacturing plant to see our capability.



This is how you can get to us.

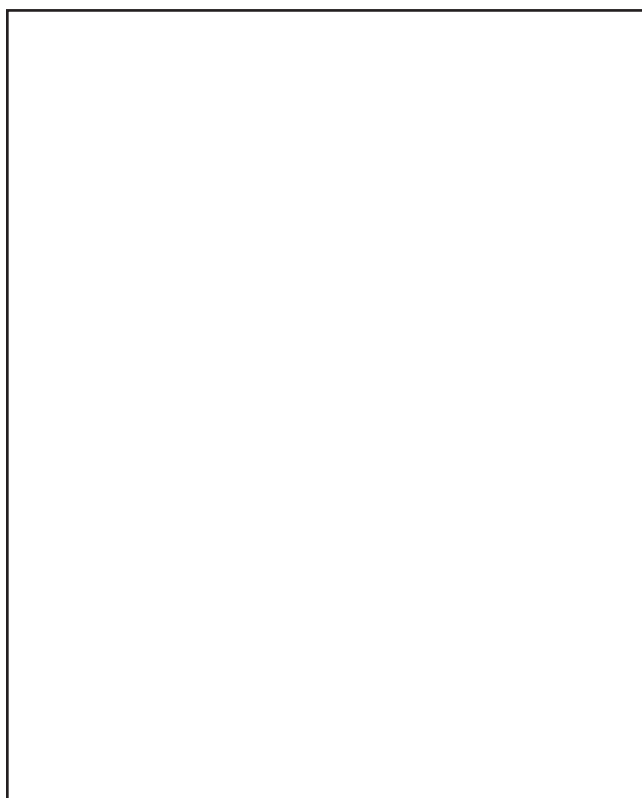

FLURO-Gelenklager GmbH

Siemensstrasse 13
D-72348 Rosenfeld / Germany
Phone +49 (0) 74 28 93 85-0
Fax +49 (0) 74 28 93 85-25
www.fluro.de
E-Mail: info@fluro.de